

T0252-4/5L 焊料工艺

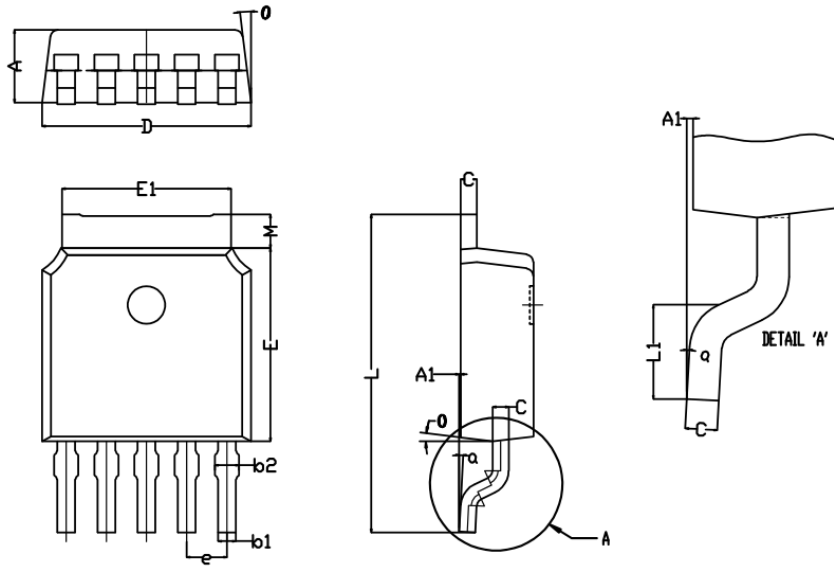

Symbol	Dim in mm		
	Min	Nom	Max
A	2.25	2.30	2.35
L1	2.90	3.00	3.10
b1	0.51	0.56	0.61
b2	0.71	0.76	0.81
C	0.46	0.51	0.56
D	6.55	6.60	6.65
e	1.27 (BSC)		
E	6.05	6.10	6.15
E1	5.23	5.33	5.43
L	9.84	10.04	10.24
A1	0.00	0.05	0.10
M	1.01	1.06	1.11
o	0°	5°	10°
α	0°	3°	6°

最大厚度: 0.3mm

最大晶粒: 3.0mm×4.0mm (单岛)

丝材: 铜线、铝线、铝带

线径: 0.8~1.7mil (铜线) 4mil~20mil (铝线) 20×4mil~80×8mil (铝带)