

PDFN5×6-8L 焊料工艺

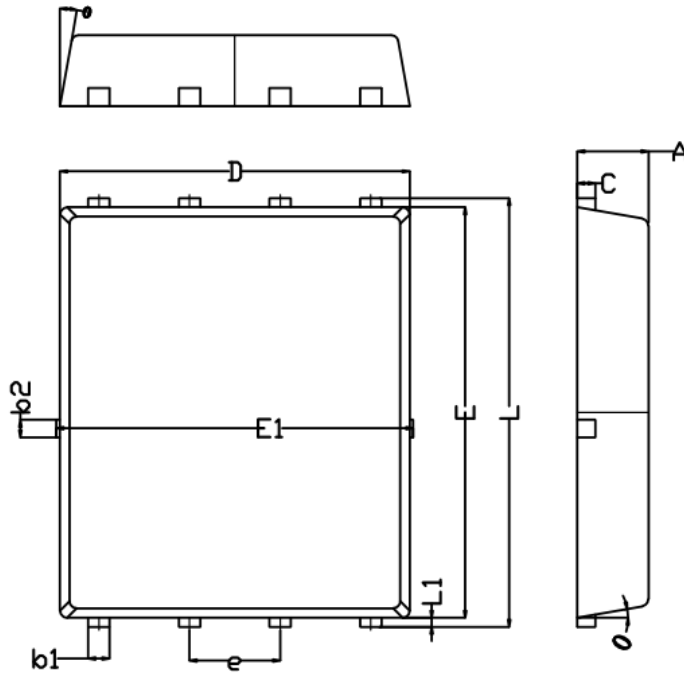

Symbol	Dim in mm		
	Min	Nom	Max
A	0.95	1.00	1.05
L1	0.075	0.125	0.175
b1	0.25	0.30	0.35
b2	0.20	0.25	0.30
C	0.204	0.254	0.304
D	4.850	4.900	4.950
e	1.270 (BSC)		
E	5.700	5.750	5.800
E1	4.950	5.000	5.050
L	5.950	6.000	6.050
o	0°	5°	10°

最大厚度: 0.150mm

最大晶粒: 3.4mm×3.8mm (单岛) 3.4mm×1.8mm (双岛)

丝材: 铜线、钎铜线、铝线、铝带

线径: 0.8~1.7mil (钎/铜线) 4mil~20mil (铝线) 20×4mil~80×8mil (铝带)