

# PDFN3×3-8L 焊料工艺

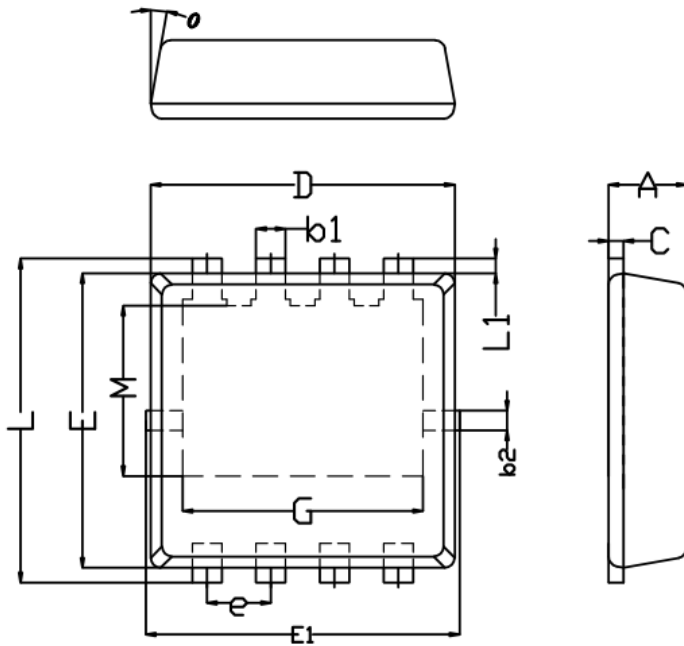

Symbol	Dim in mm		
	Min	Nom	Max
A	0.75	0.80	0.85
L1	0.10	0.15	0.20
b1	0.25	0.30	0.35
b2	0.15	0.20	0.25
C	0.10	0.15	0.20
D	3.050	3.100	3.150
e	0.650 (BSC)		
E	2.950	3.000	3.050
E1	3.150	3.200	3.250
L	3.250	3.300	3.350
M	1.685	1.735	1.785
G	2.400	2.450	2.500
o	0°	5°	10°

最大厚度: 0.150mm

最大晶粒: 1.6mm×2.3mm (单岛) 1.6mm×0.9 mm (双岛)

丝材: 铜线、钎铜线、铝线

线径: 0.8~1.7mil (钎/铜线) 4mil~20mil (铝线)