



型号/TYPE: SLS4832

N沟道增强型双MOS管 N Channel Enhancement mode Field Effect Transistor

主要特性/Features

先进的沟槽工艺技术 Advanced trench process technology

高密度单元设计, 超低导通电阻 High density cell design for ultra low on-resistance

高功率和电流处理能力 High power and current handling capability

适用于锂电池组应用 Ideal for Liion battery pack applications

应用/Application

适用于锂电池组应用 Ideal for Liion battery pack applications

印字/MARKING 引脚定义/pin definition

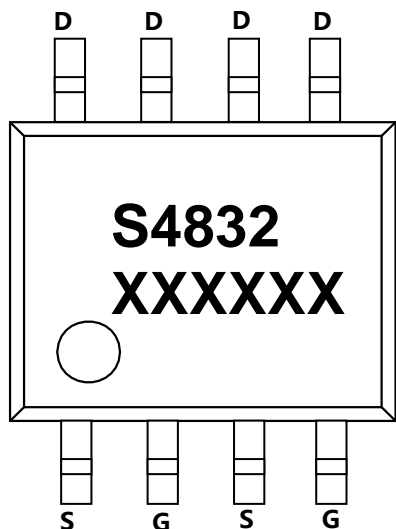



极限参数/N-Channel Absolute maximum ratings(Ta=25°C)

参数Parameter	符号Symbol	数值Value	单位Unit
Drain-Source Voltage	V_{DS}	30	V
Gate-Source Voltage	V_{GS}	±20	V
Continuous Drain Current	I_D	8	A
Pulsed Drain Current (note1)	I_{DM}	30	A
Power Dissipation	$P_D (Ta=25^\circ C)$	1.5	W
Thermal Resistance Junction to Ambient(note2)	$R_{\theta JA}$	100	°C/mW
Junction Temperature	T_j	150	°C
Storage Temperature	T_{stg}	-55 ~ 150	°C

电性能参数/ P-Channel Electrical characteristics (Ta=25°C)

参数 Parameter	符号 Symbol	测试条件 Test Conditions	最小值 Min	典型值 Typ	最大值 Max	单位 Unit
静态参数/Static Characteristics						
Drain-Source Breakdown Voltage	$V_{BR(DSS)}$	$V_{GS}=0V, I_D=250\mu A$	30			V
Gate Threshold Voltage(note3)	$V_{GS(th)}$	$I_D=250\mu A, V_{GS}=V_{DS}$	0.6		1.4	V
Gate-body leakage current	I_{GSS}	$V_{GS}=\pm 20V, V_{DS}=0V$			±100	nA
Zero gate voltage drain current	I_{DSS}	$V_{DS}=24V, V_{GS}=0V$			1	μA
Drain-source on-resistance(note3)	$R_{DS(ON)}$	$V_{GS}=10V, I_D=8A$			15	mΩ
		$V_{GS}=4.5V, I_D=5.0A$			17	
Drain-Source Diode Forward Voltage(note3)	V_{SD}	$V_{GS}=0V, I_{SD}=1.0$	0.5		1.0	V
动态参数/Dynamic Characteristics(note4)						
Input Capacitance	C_{iss}	$V_{DS}=15, V_{GS}=0V,$ $f=1MHz$		113		pF
Output Capacitance	C_{oss}			17		
Reverse Transfer Capacitance	C_{rss}			125		
开关参数/Switching Characteristics(note4)						
Turn-on delay time	$t_{d(on)}$	$V_{DS}=5V, V_{GS}=5V,$ $R_L=1.8\Omega, R_{GEN}=3\Omega,$		5.7		ns
Turn-on rise time	t_r			4.8		ns
Turn-off delay time	$t_{d(off)}$			36		ns
Turn-off fall time	t_f			7		ns



封装外观尺寸/SOP8 Package Information

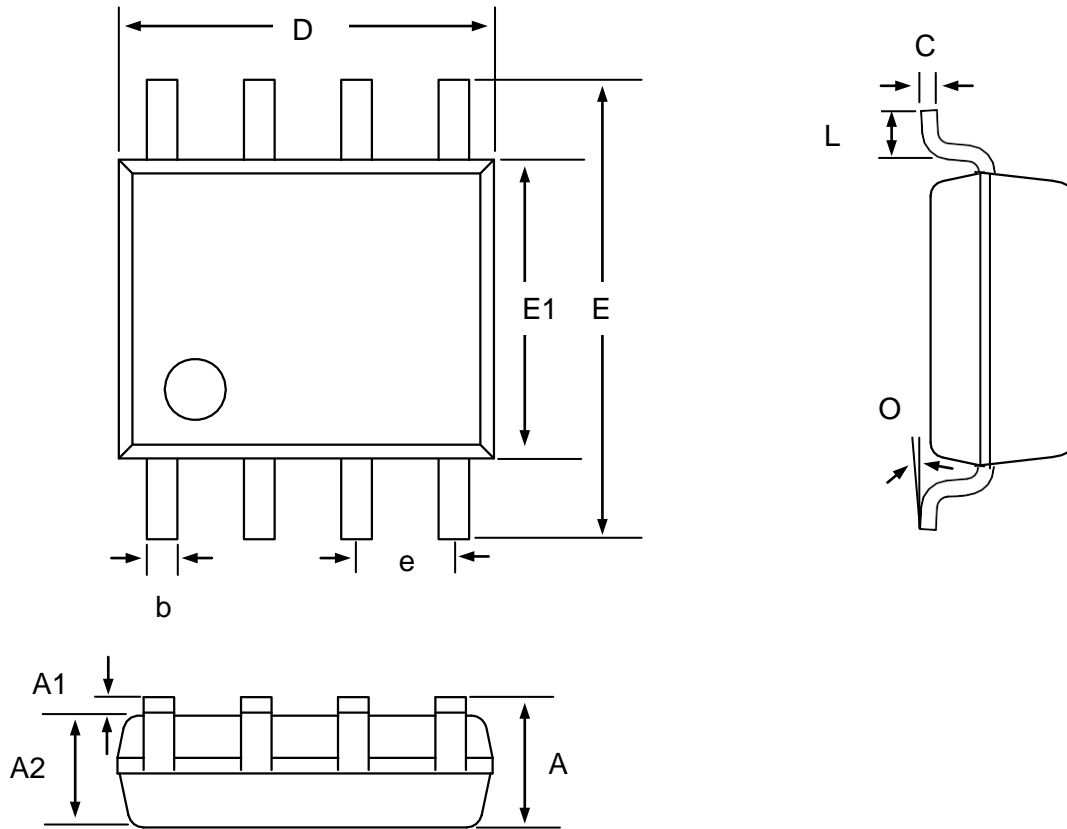

Symbol	Dim in mm		
	Min	Nor	Max
A	1.350	1.550	1.750
A1	0.100	0.175	0.250
A2	1.350	1.450	1.550
b	0.330	0.420	0.510
c	0.170	0.210	0.250
D	4.800	4.900	5.000
e	1.270(BSC)		
E	3.800	3.900	4.000
E1	0.400	0.835	1.2700
L	0°	4°	8°